

NAILING HEAD PNEUMATIC STAPLER FOR GANTRY CRANES

C38/90 PJRC1

Code : 101C3890W

■ Technical description

Code	101C3890W
Dimensions	418 / 265 / 520 mm
Weight	14,50 kg
Magazine capacity	1 000
Projectile lengths	45 - 90 mm
Projectile diameter	2,50 x 3,80 mm
Operating pressure	5 à 8 bars
Air consumption	4,10 l/tir
Acoustic characteristics	$L_{wa,1s}$: 98.38 dB(A) $K_{WA,1s}$: 2.5 $L_{pa,1s}$: 93.0 dB(A) $K_{pA,1s}$: 2.5

■ Application

Timber-framed houses.
Fixing OSB panels or plasterboard to a timber frame. Specially designed for Weinmann and Mach Diffusion multi-function bridges.

Projectiles

16 F



16°
45 à 90 mm
Ø 2.5 à 3.8 mm
Ø head 5.5 à 7.1 mm

SCRAILS



SCRAILS[®]
50 à 90 mm
Ø 2.8 à 3.8 mm
tête torx ou philips



■ Benefits

- Large-capacity magazine (800 to 1000 nails)
- Electric nail presence sensor.

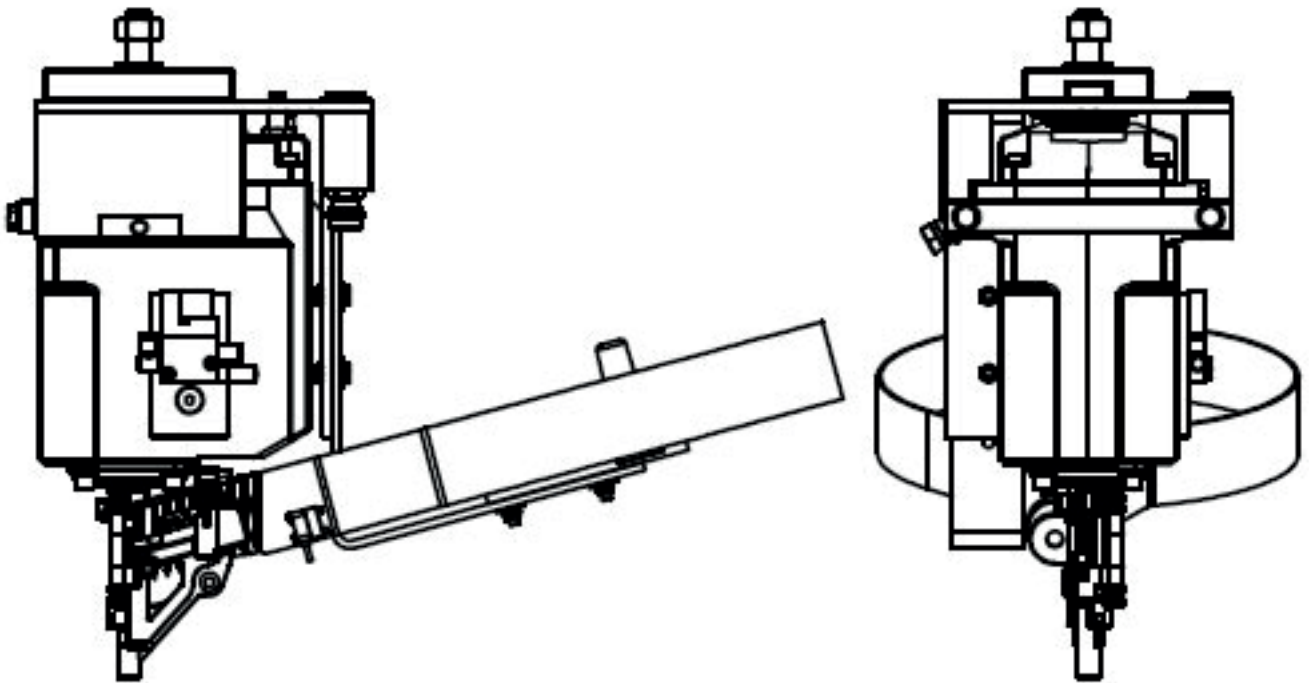

Subject to change without notice. Alsafix cannot be held responsible in the event of installation without prior calculation and testing specific to each case.